

Movable Partition

01

Company Profile



06

Semi-automatic Solid Movable Partition



18

Glass Movable Partition



02

Manual Solid Movable Partition

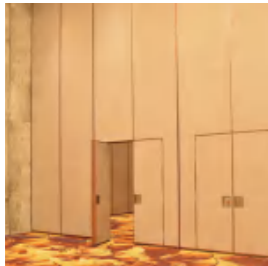

10

Fully-automatic Solid Movable Partition

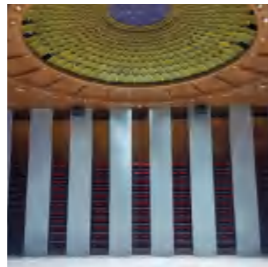

24

Electric Vertical Folding Partition

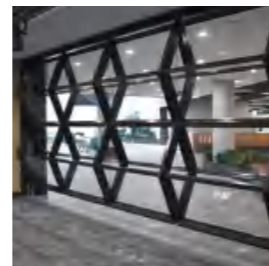

Company Profile

Guangzhou DAITACHI Decoration Engineering Co., Ltd was established in 2009, It is a technological innovation enterprise that integrates research, development, design, production, maintenance and sales of electric movable partition walls. DAITACHI is a industry and trade integration company, Our Factory is in Foshan and our office in Guangzhou, Guangdong province.

DAITACHI, The co-founder and core R&D team has over 10 years of industry experience in the field of fully-automatic movable partition wall, semi-automatic movable partition wall, fixed movable partition wall and a full range of movable partition walls with a reliable quality and competitive price, including type65, type85, type100, type120,etc and also can be OEM according to your requirement to produce,etc.

Combining the domestic and foreign technology, DAITACHI has mainly focused on researching and developing the newest electric vertical folding partition walls and finished office phone pods for the market.

Our movable partition walls are suitable for office space, hotel banquet hall, shopping mall, exhibition hall, gymnasium, schools, conference centers, auditoriums, multi-purpose halls, large production workshop and other professional venues,etc.

Welcome to contact us and visit us! 



Movable partition is also called movable wall or sound absorbing movable partition wall.

From the operating mode of movable partition, there are three types: manual movable partition, semi-automatic movable partition and fully automatic movable partition.

It is easy to install, easy to operate, stable and highly flexible, soundproof and environmentally friendly.

Be mainly used to divide the space so that the space can be used flexibly, and it can be used independently.

Wide range of applications: multifunctional meeting rooms, hotels, hospitals, government office buildings, Exhibition venues, national institutions, schools, multi-function halls, banquet halls, Office building, boutique display shop, bank, securities, factory, station, clubs, shopping malls, etc high decoration and design of interior spaces in public or commercial buildings.



Manual Solid Movable Partition

A movable partition can be applied in any venue. It can divide a large space into two or more spaces without taking up much space area. The partition structure is simple but has very nice styles and many functions like flexible assembly, convenient operation, fireproof and sound insulation.



MODELS

Type65, Type85 and Type100 are our main solid partition models and they can be customized according to your requirements. The products are designed with quality and practicality in mind, and also be flexible and easy to operate.

The frame and track are all made of 6063T6 aluminum alloy material. The horizontal and vertical seals are very tight, the panel cavity is infilled with acoustical insulation. In most cases, steel plate and other sound-insulation materials can be added to the inner sides of the panels if high-efficiency sound insulation is required.

FINISH OPTIONS

A variety of finish options of Melamine boards, Inkjet landscape paintings, Lacquered glass and Acoustic wallcovering, etc. The melamine finishes are available in a wide range of colors and styles. Landscape paintings is an important feature of our brand and is very aesthetically pleasing and customers need to provide their own clear pictures.

SELECTION OF SUBSTRATE BOARD

For Sound-insulation

Glass-magnesium board , Gypsum board, High-density and MDF board.

For Fire protection

Fire-retardant plywood, Eco-board, Glass-magnesium board, Gypsum board.

For Waterproof

Glass-magnesium board, Gypsum board and Aluminium veneer board.



PARKING / STACKING PATTERNS

F-shape, H-shape, E-shape, L-shape, Y-shape, and straight line typical layouts, etc are various of partition parking / stacking patterns.

The flexibility of space usage is maximized.

Panel can be easily and turned, moved at different angles or stacked to the wall or a far away niche.

PASS DOOR

The pass door has a standard single leaf door and double leaf door design. The bottom of the pass door has an automatic drop seal system, the whole panel is completely sealed, which can be very good at preventing sound leakage.

Suitable for Restaurant, Hotels, Office, Business negotiation room, Exhibition Hall, Computer room, Hospitals and many other venues. Suitable for Restaurant, Hotels, Office, Business negotiation room, Exhibition Hall, Computer room, Hospitals, and many other venues.



MODELS	Type65	Type85	Type100
OPERATION	Individual panel , Manually-operated		
THICKNESS	65mm	85mm	100mm
PANEL WIDTH	600-1220mm		
MAX. HEIGHT	5000mm	6000mm	17000mm
SUSPENSION	Center / Two points suspension		
SOUND INSULATION	28 - 34db	35-45db	43-54db
TOP / BOTTOM SEALS TRAVEL DISTANCE	23mm-25mm	23mm-25mm	23mm-40mm
SUBSTRATE BOARD	MDF Board, Fire-retardant Plywood, Glass-Magnesium Board, Gypsum Board, Aluminum Veneer Board, High Density Board		
FRAME	Black / Silver is standard color. Optional customization by powder coating, electrophoresis or Wood grain		
FINISHING	Melamine board, HPL Board, Inkjet landscape painting, Lacquered glass, Wallpaper, 9-12mm Invisible frame hard cover acoustic fabric (leather), 9-12mm Hard/Soft cover acoustic fabric (leather) and other materials		
PANEL WEIGHT	20-30kg/m ²	28-38kg/m ²	35-50kg/m ²

The maximum height of the single-point suspension partition is 6.5meters

Color of the frames can be customized only when the area of the partition wall is larger than a certain amount of square meters.



Semi-automatic Solid Movable Partition

Semi-automatic partition has all the advantages of manual partition, but its biggest advantage is the electrically controlled top and bottom retractable mechanism.

The semi-automatic movable partition is controlled by PCB control board and microcomputer. Use safe voltage DC 24V control. The operation is convenient and easy, which greatly saves the time and energy in moving the wall.

MODELS

Type85, Type100, Glass85, Glass100. Semi-automatic partition is the modified version of manual partition. They can also be customized according to the requirements of customers. The height is unlimited, and the solid panel can be made up to 17 meters high.

CONTROL SYSTEM

Electrically-operated and manual operation. When panel is pushed into position and two panels are joined together, the top and bottom seal will automatically activate and lock panel.

When unlocking the panels, press the remote control to retract the seals of all the panels at once.

MODELS	Type85	Type100	Glass85	Glass100
OPERATION	Individual panel, Semi-automatically-operated, Remote controlled			
THICKNESS	85mm	100mm	85mm	100mm
PANEL WIDTH	600-1220mm			
MAX. HEIGHT	6000mm	17000mm	4000mm	
MANUAL OPERATION	Optional			
SUSPENSION	Center / Two points suspension			
TOP / BOTTOM SEALS TRAVEL DISTANCE	25mm	25mm - 40mm	23mm - 25mm	23mm - 30mm
PANEL WEIGHT	28-38 kg/m ²	35-50 kg/m ²	42-46 kg/m ²	50-55 kg/m ²

Optional unlocking feature

1. Button control.

There is a small button on concave side of each panel. Press the button to retract the seals of panels one by one.

2. Manual operation function.

A handle can be used to unlock the panel which ensures normal operation in the event of power down.

3. Single-control switch.

It is installed on the wall to power on or off the whole partition wall. When it is switch off, the partition is unusable.

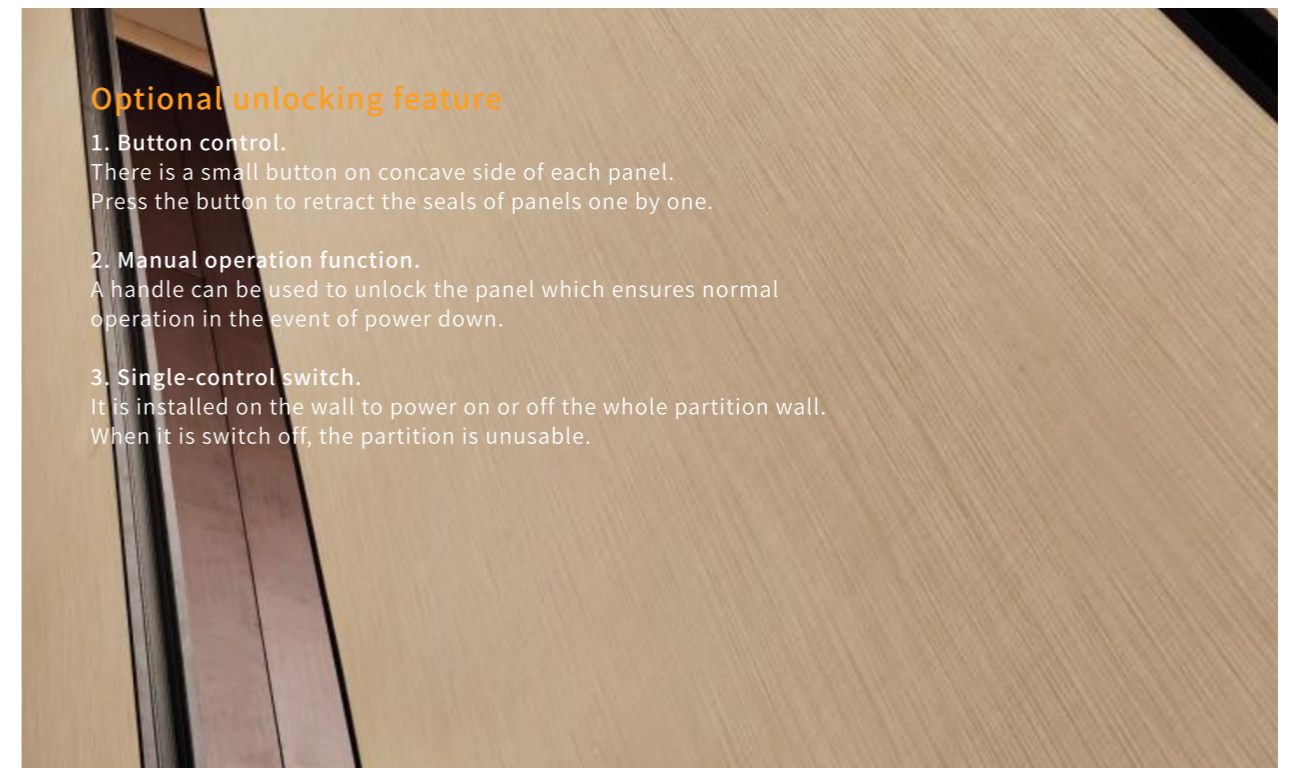

Scan and watch video

Semi-automatic Solid System Operation

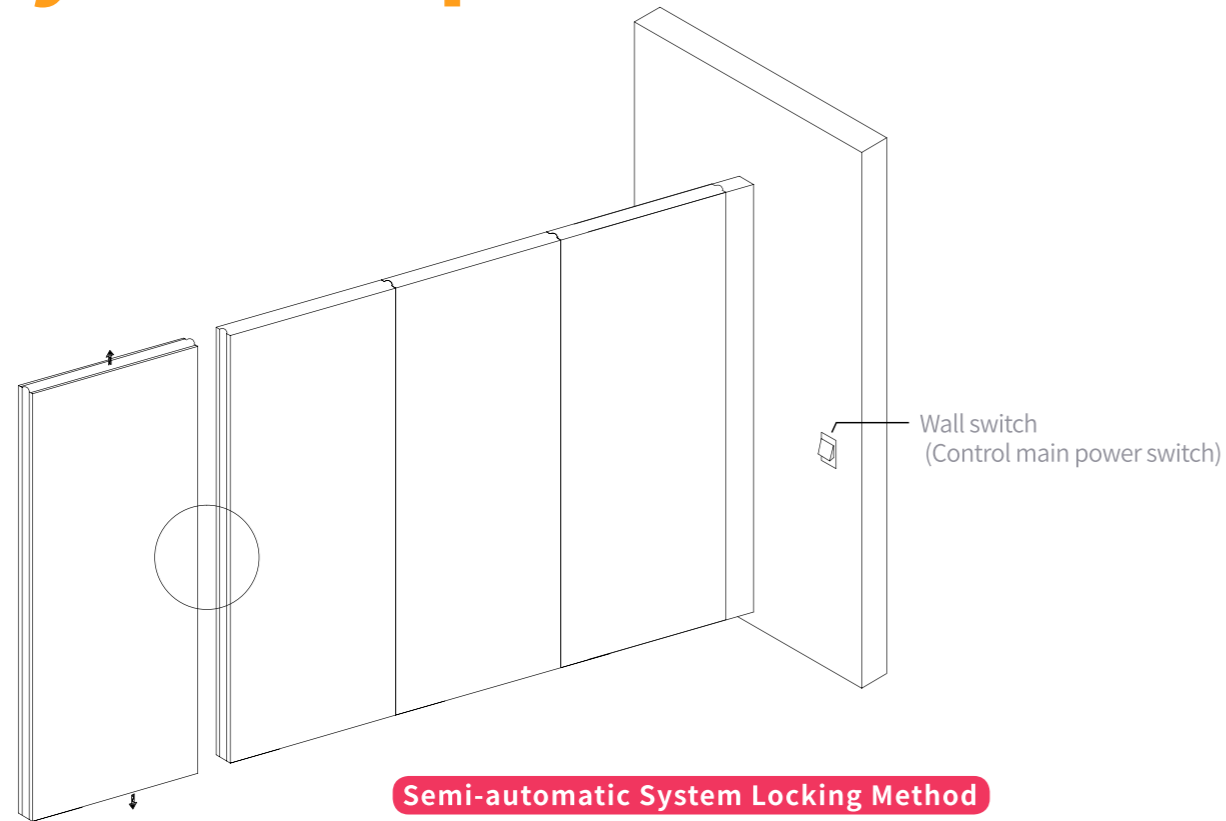

Semi-automatic System Locking Method

When the panel is pushed into position and two panels are joined together, the top and bottom seal will automatically activate and lock the panel.

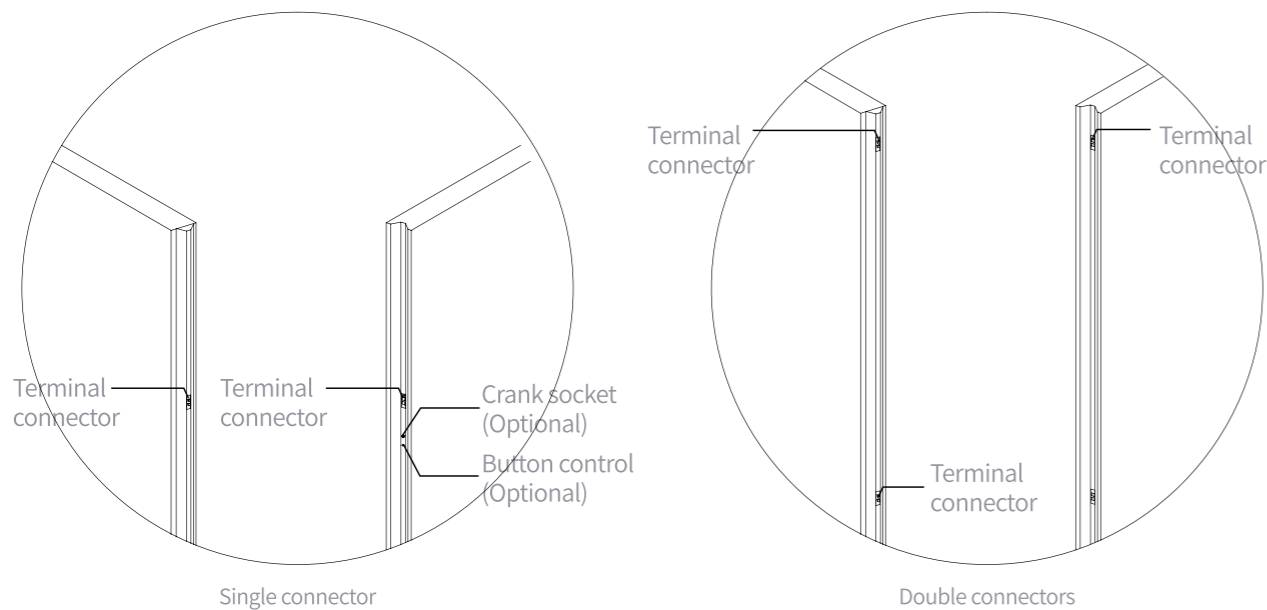

Semi-automatic Standard Feature

1. Button control + Remote control

Semi-automatic Optional Features

1. Remote control + Manual operation
2. Button operation + Remote control + Manual operation

The wall switch is customer owned or factory supplied and can be replaced with a switch with a keyhole if required.

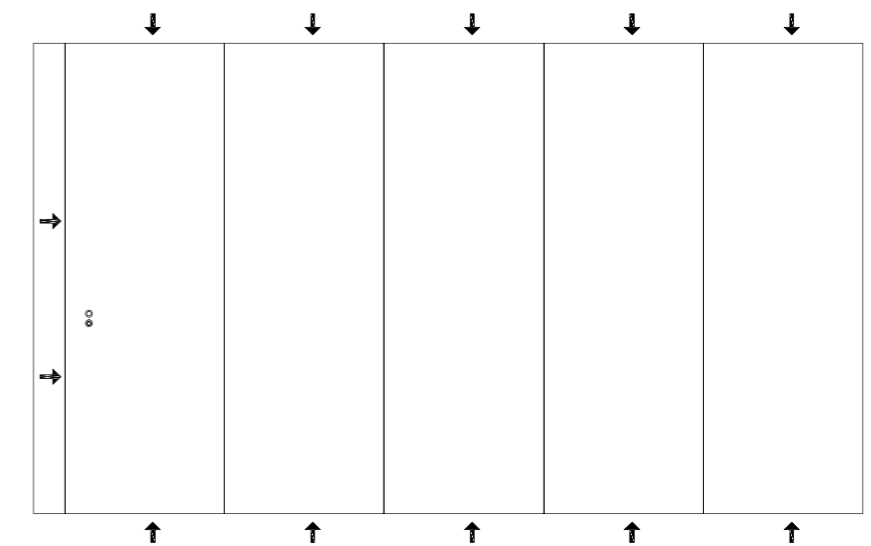
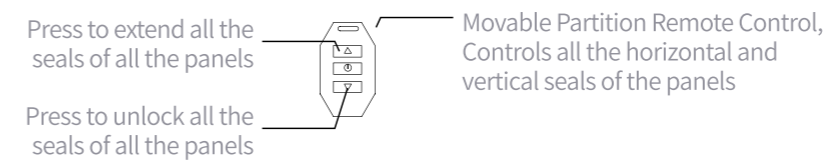
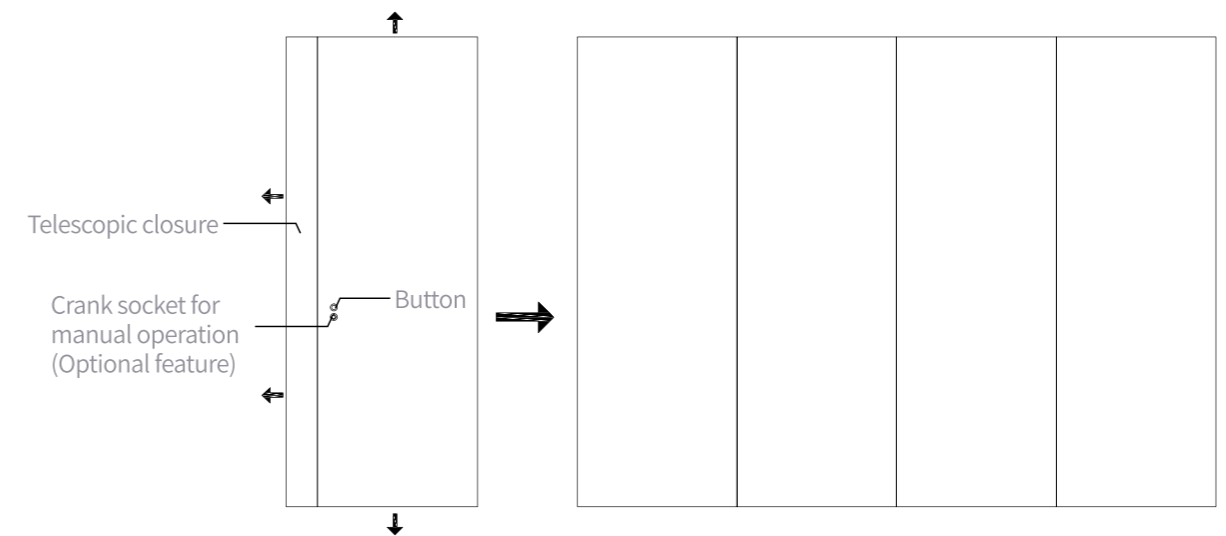



Fully-automatic Solid Movable Partition

Industrial programmable control, automatic control of each panel. The motor of each panel is equipped with an optical encoder for position control of each panel.

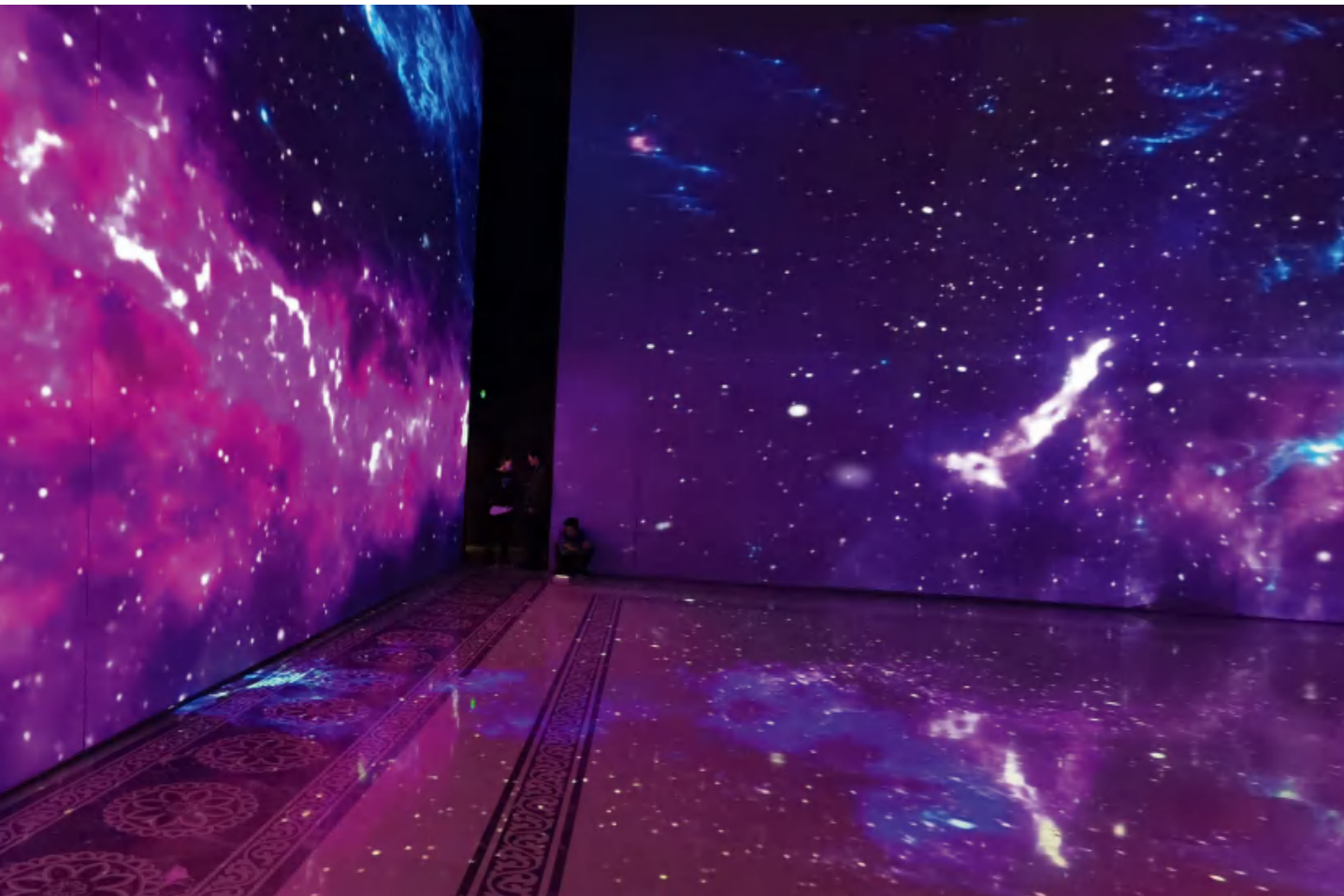

MODELS

Type85, Type100, Glass85, Glass100 and Simplicity35 are the main models of fully-automatic partition system. They can also be customized according to the requirements of customers. The height is unlimited, and the solid panel can be made up to 15 meters high.

ELECTRICAL SYSTEM

- The main power drive motor controls the extension and storing of the panels.
- Motor-controlled Top and bottom retractable mechanism seals and telescopic closure panel.
- Travelspeed:100~250mm/s

PARKING/STACKING LAYOUTS

F-shaped, Y-shaped, straight-line and other layouts. Automatic directional turning with arc shape joint.



SYSTEM FEATATURES

- 6063T6 aluminum alloy track
- Technology special motor
- Fully-automatic control system, one-touch operation of the entire partition.
- Superior sound insulation
- Suitable for hotels, conference centers, offices and other places

SECURITY SYSTEM

1. The partition can be equipped with a obstacle sencer to detect the coming object. The partition will automaticall stop when is it blocked.
2. The system has a power failure protection function, when an accidental power failure,the system will maintain and remember the position of each panel in the system in the event of power failure.when the power is restored the system will automatically execute the unfinished work.
3. Equipped with a keyswitch to prevent non-manager from operating the system.
4. Wall-mounted switch or remote control, can fully control automatic extending, storing, locking, unlocking and other operating instructions of the panels.



Scan and watch video

MODELS	Type85	Type100	Glass85	Glass100	Simplicity35
OPERATION	Individual panel, Electrically-operated, Remote controlled				Individual/panel, continuously-hinged Electrically-operated, Remote controlled
THICKNESS	85mm	100mm	85mm	100mm	35mm
PANEL WIDTH	600-1220mm		600-1200mm		600-1200mm
MAX. HEIGHT	7000mm	15000mm	4000mm		3500mm
SUSPENSION	Center / Two points suspension, Drive system				
TOP / BOTTOM SEALS TRAVEL DISTANCE	25mm	25mm - 40mm	23mm - 25mm	23mm - 30mm	/
PANEL WEIGHT	28-38 kg/m ²	35-50 kg/m ²	42-46 kg/m ²	50-55 kg/m ²	25-34 kg/m ²

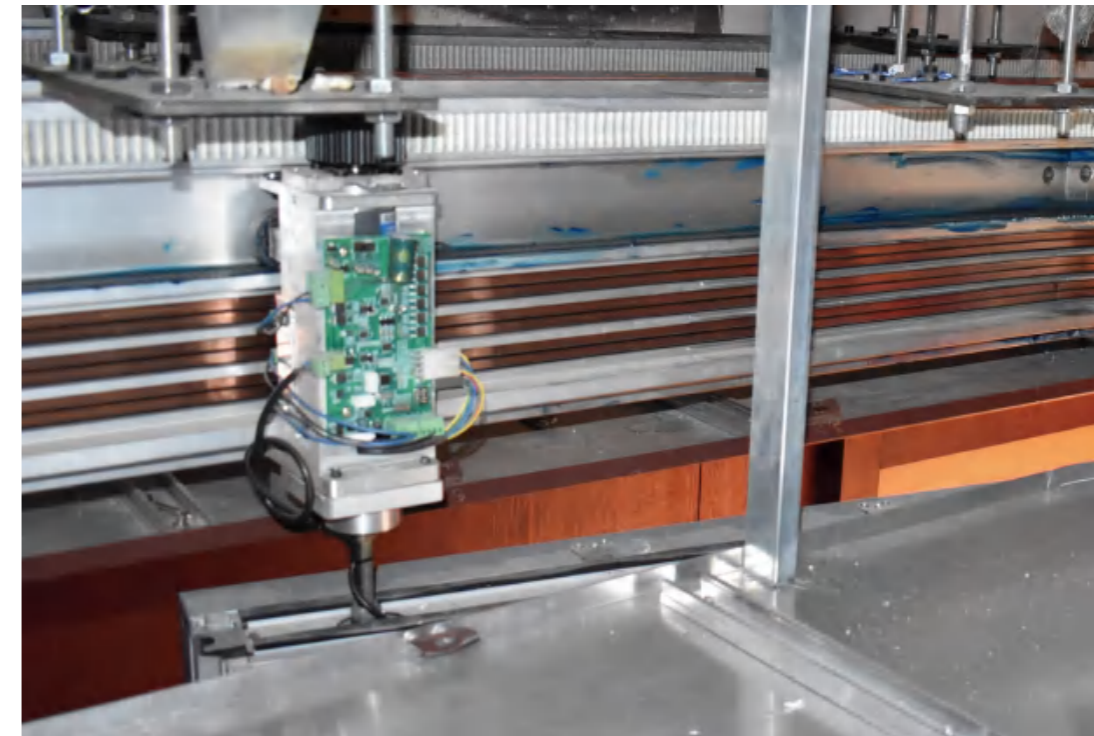

Fully-automatic Solid External Wires Layout

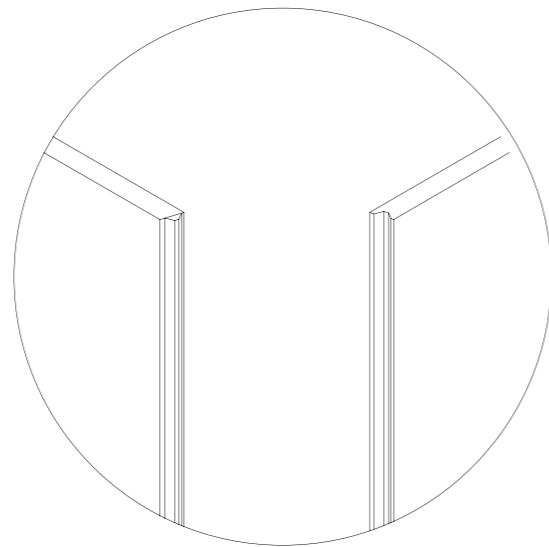
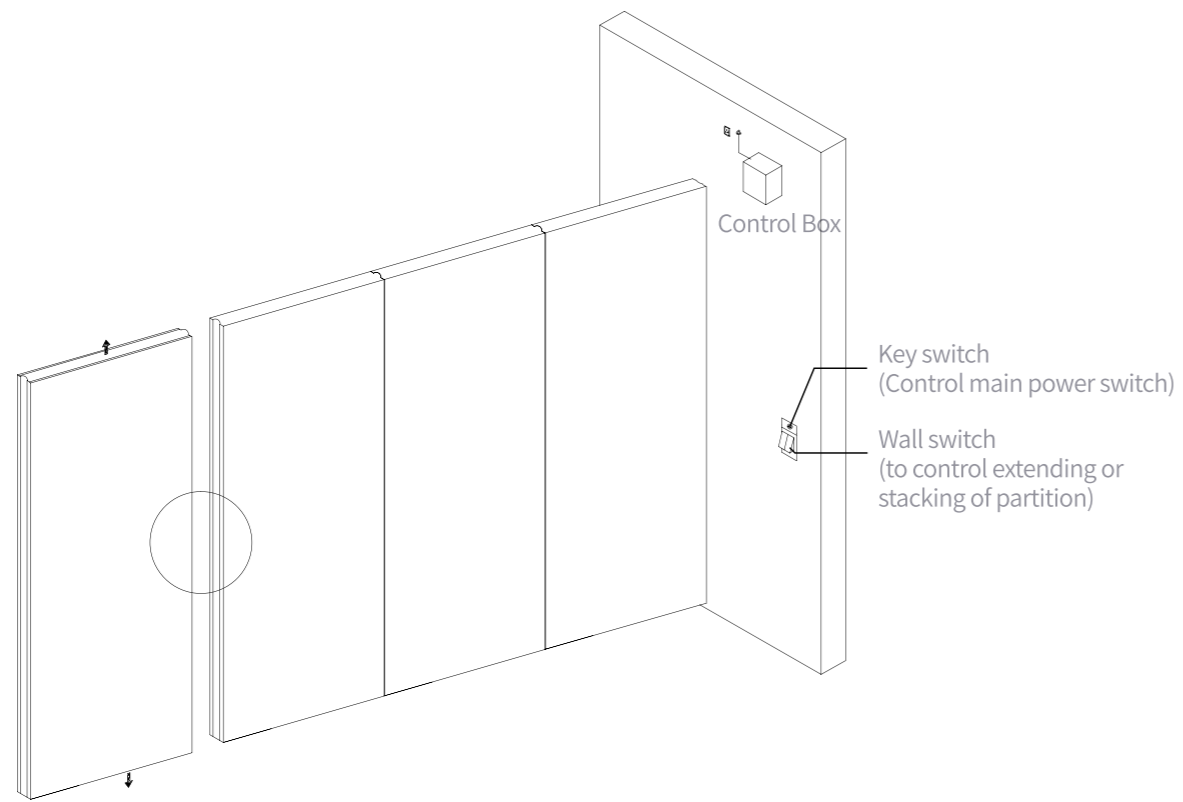

Fully-automatic System Locking Method

When the panel is moved into position and two panels are joined together, the top and bottom seal will automatically activate and lock the panel.

Fully automatic Standard Features

1. Wall switch control with key switch + Remote control
The wall switch is provided by the factory, not equipped with a Stop Switch, it can be provided by the factory if required.

Caution

Do not stand underneath or enter or exit at will while the panels are operating.

Do not press pause button at will without special circumstances.

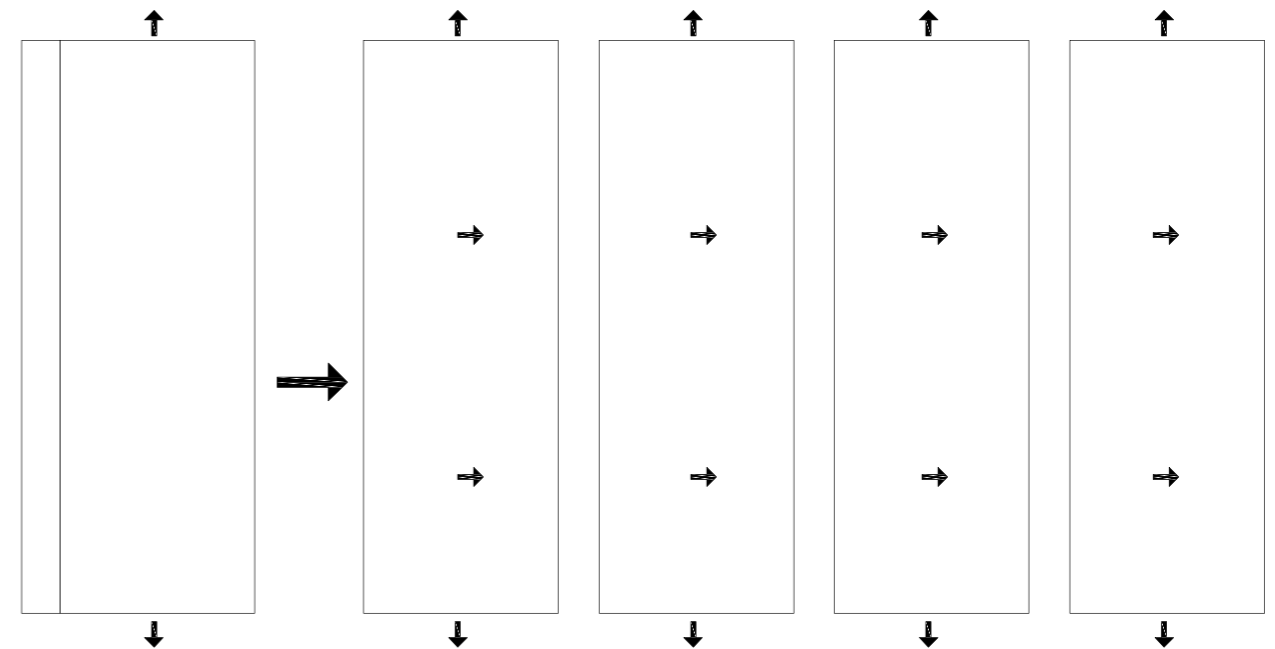
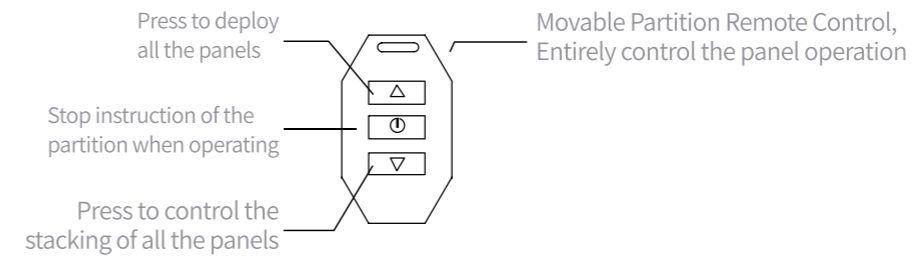



Glass Movable Partition

The Glass movable partitions are very stylish nice-looking. The range of glass materials available is extensive and versatile. The glass partition has the top and bottom retractable mechanism like the traditional solid partitions do providing a complete airtight seal for soundproofing and privacy. This glass partition can be mixed with same framed solid partition walls.

MODELS	Glass65	Glass85	Glass100
OPERATION	Individual panel, Manually-operated		
GLASS THICKNESS	Single layer of 8mm, 10mm	Double layers of 6, 8mm	Double layers of 6 - 8mm
FRAME THICKNESS	65mm	85mm	100mm
PANEL WIDTH	600-1200mm		
MAX. HEIGHT	4000mm		
SUSPENSION	Center/ Two points suspension		
SOUND INSULATION	26 - 28db	34-39db	35 - 41db
TOP / BOTTOM SEALS TRAVEL DISTANCE	Floor latch	25mm	30mm
FINISH OPTIONS	Tempered glass, Ultra-white tempered glass, Dimming glass, Lacquered, Sandblasted, Frosted, Acid-etched, Plexiglass, and other art glass such as Dimming glass, Fluted Textured Glass and Wired glass, etc.		
PANEL WEIGHT	32 - 36KG/ sq.m	42 - 46KG/ sq.m	50 - 55KG/ sq.m
CLOSURE	/	Hinged panel / Telescopic closure panel	

Maximum height of Glass hinged panel is 3500mm.



MODELS

Glass65, Glass85 and Glass100 are the three main models of the framed glass partition. They can be customized according to the customer's needs. It uses all kinds of tempered glass and art glass in the thickness from 6mm to 10mm. Its design is also quality and safety oriented, followed by its stylish appearance.

The frame and track are all made of 6063T6 aluminum alloy material. The horizontal and vertical seals are very tight. The frames need at least 60mm of space left and right and 100mm of space up and down to hide the retractable mechanism. The frames of double-glazing are completely covered by a lacquered finish on the inner sides of the glass.

FINISH OPTIONS

A variety options of glass finishes such as Tempered glass, Ultra-white tempered glass, Sandblasted, Frosted, Lacquered glass, Acid-etched, plexiglass, Dimming glass and other art glass such as Fluted Textured Glass and Wired glass.

PARKING/STACKING PATTERNS

F-shape, H-shape, E-shape, L-shape, Y-shape, and straight line typical layouts. Various partition parking/stacking patterns. The flexibility of space usage is maximized. panel can be easily and turned, moved at different angles or stacked to the wall or a far away niche.

PASS DOOR

Double glazed movable wall has a standard single leaf door and double leaf door design. The bottom of the pass door has an automatic drop seal system, the whole panel is completely sealed, which can be very good at preventing sound leakage.

Simplicity 35 (Arc-shaped)

This type of glass partition's glass and track are arc-shape and is fully automatic operating, also with foggy and patterned function.

This type of frameless partition has a simple structure of top and bottom clips. The range of glass materials available is extensive. Mostly used in shopping malls, shopfronts, office and meeting room.

35mm thick and 110mm front height of the top and bottom clips. Simplicity35 can be made to a folding wall by hinging the panels together. Under the bottom clips is the brush seals and floor bolt to fix the partition. The color of the clips is usually silver.

FINISH OPTIONS

A variety options of glass finishes such as Tempered glass, Ultra-white tempered glass, Curved glass, Sandblasted, Frosted, Lacquered glass, Acid-etched, plexiglass, Dimming glass and other art glass such as Fluted Textured Glass and Wired glass.

PARKING/STACKING PATTERNS

Two-ponits panel can be easily turned, moved at different angles and stacked to the wall or a far away niche.

The single-ponit or continuously hinged panels move in a straight or curved line to stacked to the wall or a niche.

PASS DOOR

A panel against the wall can be designed as a pivot door.

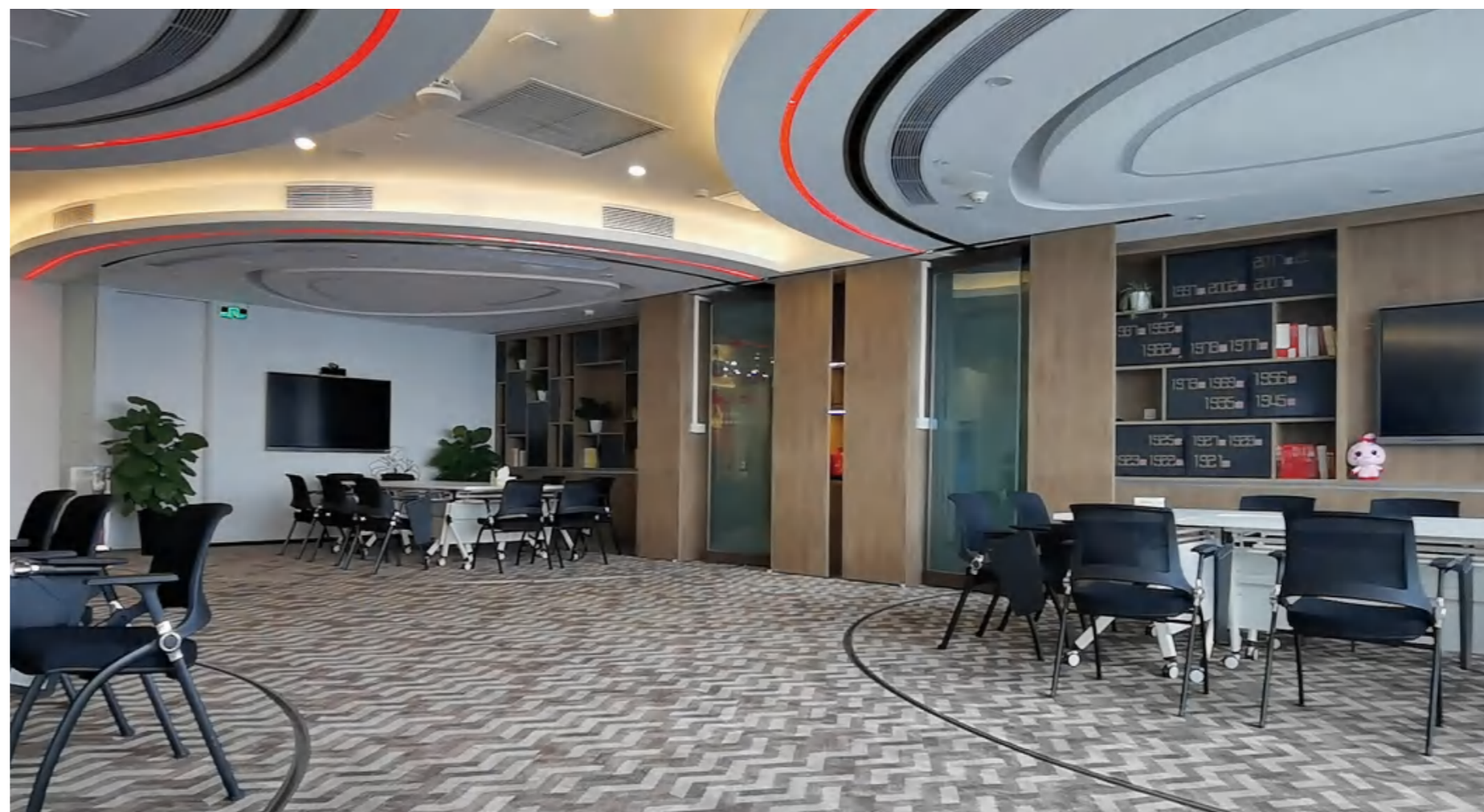

MODELS	Simplicity35
OPERATION	Individual panel / Continuously hinged, Fully-automatically-operated
GLASS THICKNESS	8 -12mm
FRAME THICKNESS	35mm Top and bottom clips
PANEL WIDTH	400-1200mm
MAX. HEIGHT	3500mm
SUSPENSION	Center/ Two points suspension
FINISH OPTIONS	Tempered glass, Ultra-white tempered glass, Dimming glass, Lacquered, Sandblasted, Frosted, Acid-etched, Curved, Plexiglass, and other art glass such as Dimming glass, Fluted Textured Glass and Wired glass, etc.
PANEL WEIGHT	25-34kg/m ²
CLOSURE	Pivot door (optional)

A pivot door can only be designed against the wall.



Scan and watch video



Electric Vertical Folding Partition

Our electric vertical folding partition is very suitable for no enough space to hide the panels.

There are 2 kinds of optional materials: Glass and Solid, also the finish can be OEM according to your demands.

Electric vertical folding partition is stored in the ceiling, no floor and no wall tracks to maximize more spaces and also is flat, rigid and light weight, etc. Be perfectly used for hotels, conference halls, schools, educational institutions, office and other fields.



Scan and watch video



The Features and Advantages:

- 1). Retracts into the ceiling to maximize more spaces;
- 2). No floor and wall tracks;
- 3). Fully automated, auto-reverse and quiet;
- 4). Easy to use, turn key operation;
- 5). Flat, rigid and light weight;
- 6). Variety of finish options;
- 7). Cost-effective and obstruction safety sensor;
- 8). Digital touch screen operator station is out standard option;
- 9). Acoustical performance warranty: 20 Years; parts warranty: 3 years.

Finish

There are many different types of optional finish.
Also can be customized according to your requirements.



Movable Partition Manufacturer with over 10 years' experience.

E-mail: info@daitachipartitionwall.com

www.daitachipartitionwall.com

